

# RoHS

REV	ECN NO.	DESCRIPTION	DESIGN	APPROVAL	DATE
A1	NEW	更换图框			2023.11.25

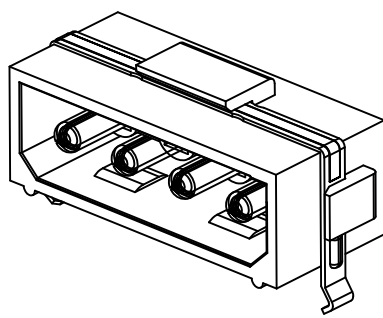
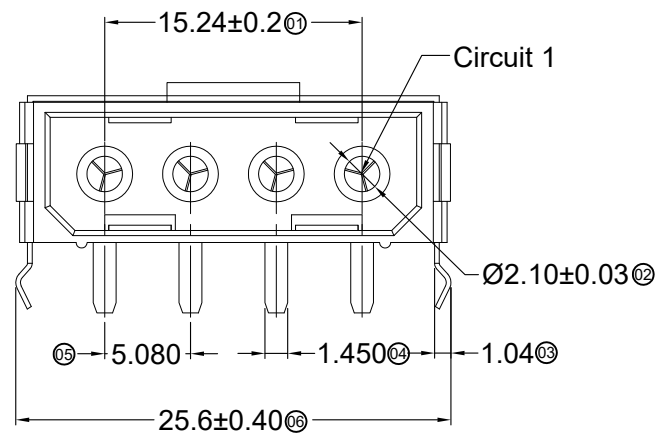

- SPECIFICATIONS**
1. Current rating: 10A AC, DC
  2. Voltage rating: 250V AC, DC
  3. Temperature range: -40°C ~ +105°C
  4. Insulation resistance: 1000MΩ Min.
  5. Withstanding voltage: 1500V AC/ minute.
  6. Contact resistance: 10mΩ Max.

**Material:**  
 Insulator: PA66 UL 94V-0(2)  
 Contact: Brass  
 Plating: Tin plated over Nickel  
 Mate with XFCN P5082 series Housing

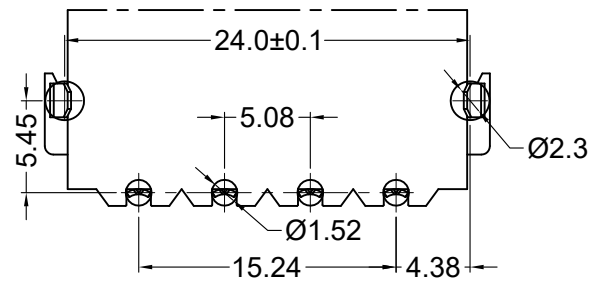
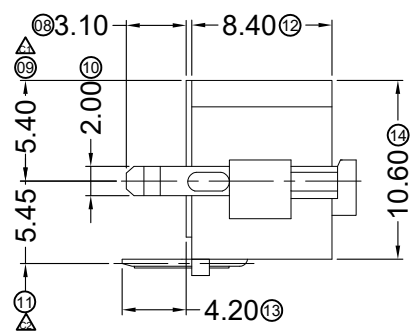
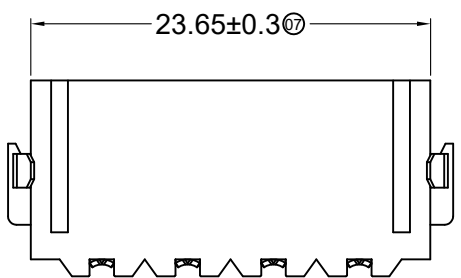

X.±0.50	X.°±
.X±0.25	.X°±
.XX±0.15	.XX°±
.XXX±0.10	.XXX°±
UNITS:	mm

**PART NO:**  
M5082RK-B-04P

**TITLE:**  
5.08mm Crimp Style Connectors

**XFCN 兴飞连接器**

0769-82001899  
 www.xfconn.com

**DWG NO:** /

THESE DRAWINGS AND SPECIFICATIONS ARE THE PROPERTY OF XFCN AND SHALL NOT BE REPRODUCED, COPIED OR CUED IN ANY MANNER WITHOUT THE PRIOR WRITTEN CONSENT OF XFCN

APPD		VIEW			
CHKD		SCALE	SHEET	REV	
DRAW	Wang	NONE	1:1	A1	
DATE	2024.01.20				