

RoHS

REV	ECN NO.	DESCRIPTION	DESIGN	APPROVAL	DATE
A1	NEW	更换图框			2023.11.25

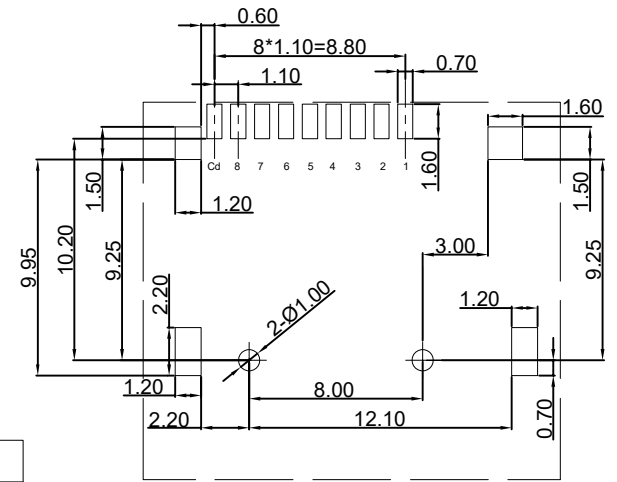

- NOTES :
- MATERIAL:
HOUSING:HIGH TEMPERATURE THERMOPLASTIC
UL94V-0 COLOR:BLACK
CONTACT: COPPER ALLOYS
OVER:COPPER ALLOYS OR STEEL
 - PLATING:
UNDERPLATE: NICKEL
CONTACT AREA: GOLD OVER NICKEL
SOLDER AREA: TIN OVER NICKEL
 - MULTIMEDIA CARD COMPATIBLE

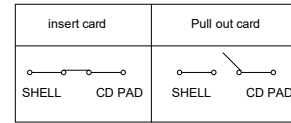
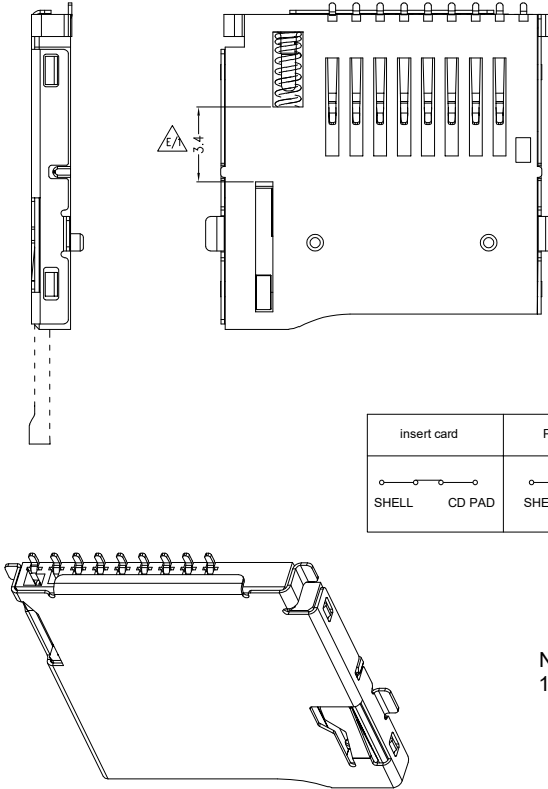
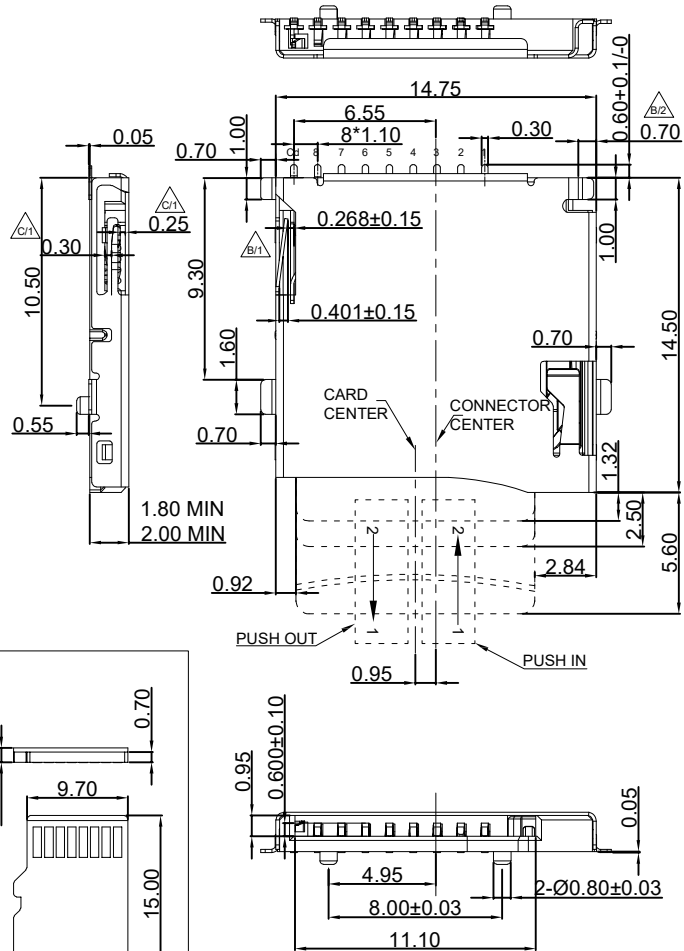
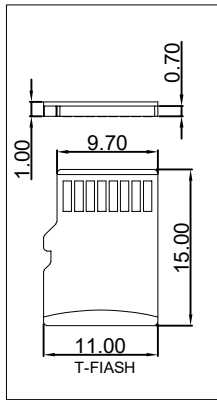

PIN NO	NAME	YTYPE	DESCRIPTION
1	DAT2	I/O/PP	DATE LINE(BIT2)
2	CD/DAT3	I/O/PP	CARD DETECT DATE LIN(BIT3)
3	CMD	PP	COMMAND RESPONSE
4	VDD	S	SUOOLY VOLTAGE
5	CLX	I	CLOCK
6	VSS	S	SUPPLY VOLTAGE GROUND
7	DATO	I/O/PP	DATE LINE(BITO)
8	DAT1	I/O/PP	DATE LINE(DIT1)
9	CD	CD	CD CD

X. 0.3	X.°±
. X±0.2	.X°±
. XX±0.08	.XX°±
. XXX±0.03	.XXX°±
UNITS:	mm

THESE DRAWINGS AND SPECIFICATIONS ARE THE PROPERTY OF XFCN AND SHALL NOT BE REPRODUCED, COPIED OR CUED IN ANY MANNER WITHOUT THE PRIOR WRITTEN CONSENT OF XFCN

PART NO:		TFW11-N1S1-2000-A		XFCN 兴飞连接器	
TITLE:		T-FLASH外焊 PUSH		0769-82001899	
				www.xfconn.com	
				DWG NO: /	
APPD	Chen ZhiQiang	VIEW			
CHKD	Liu Wei	SCALE	SHEET	REV	
DRAW	Chen HongJiang	SCALE	1/2	A1	
DATE	2024.08.19	NONE			

RoHS

REV	ECN NO.	DESCRIPTION	DESIGN	APPROVAL	DATE
A1	NEW	更换图框			2023.11.25

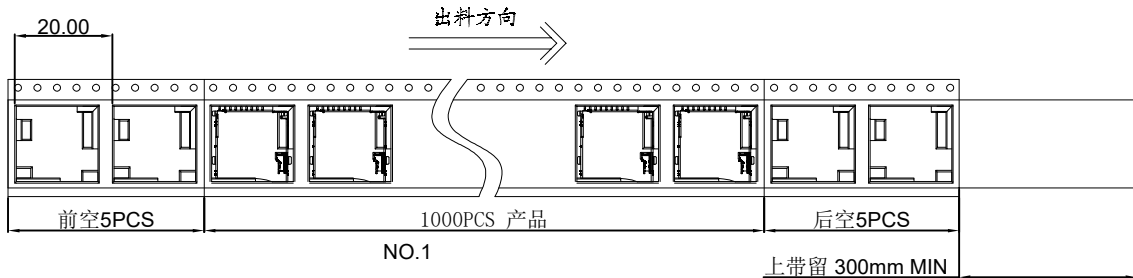
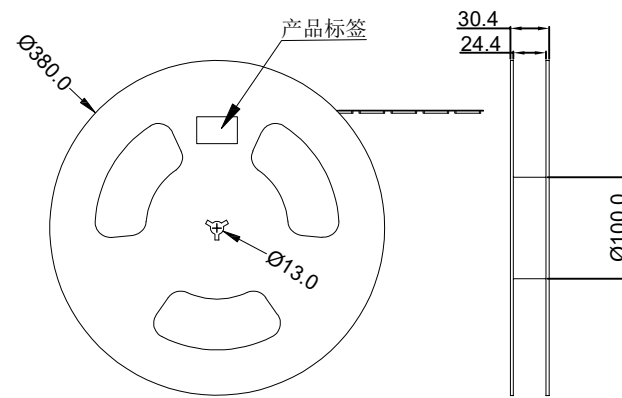
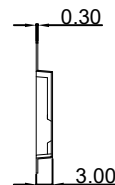
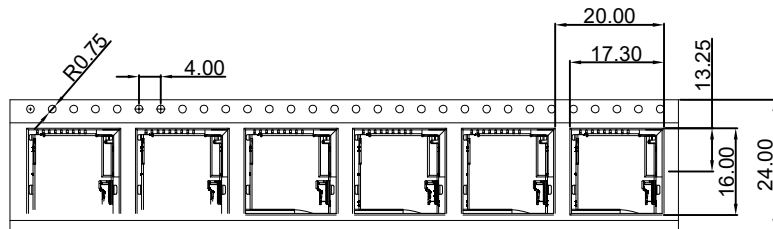

NO.2

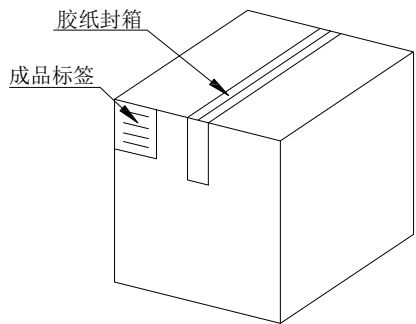

纸箱规格: 340*340*385

NO.4

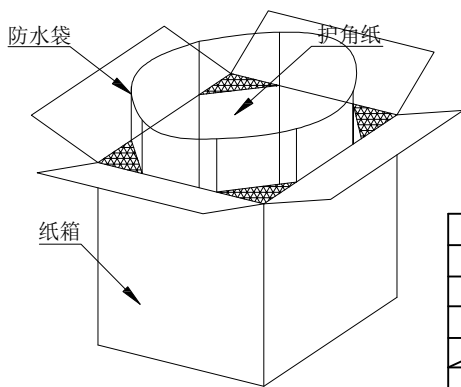
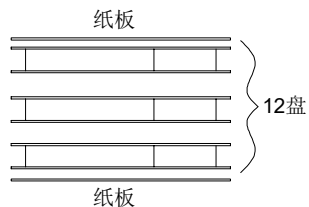

NO.3

1. 材质要求:

- 1.1 纸箱的材质要求为K-K;外形尺寸为34*34*38.5CM;
- 1.2 卷盘的材质为PS;卷盘的外形尺寸为φ380*30.4;
- 1.3 卷带的材质为PS;卷带的外形尺寸为20200*24.00*3.0mm

2. 包装要求:

- 2.1 将卷带放入包装机后, 前空5PCS, 后放产品1000PCS,再后空5PCS;上带留 300MM长度。
- 2.2 将包装好的产品从包装机上取下并包装好;
- 2.3 把累叠好的12盘(共计12Kset),用防水袋包装内附干燥剂, 上下放纸板放入纸箱内;
- 2.4 把包装好的成品打包封箱, 并在纸箱外贴上标签

备注:

1.若有未装满之零数, 必须用泡棉塞满2.针对于包装方式可根据客户要求包装。

X. 0.3	X. °±	PART NO: TFW11-N1S1-2000-A	XFCN 兴飞连接器			
. XX ± 0.2	. X ° ±					
. XX ± 0.08	. XX ° ±					
. XXX ± 0.03	. XXX ° ±					
UNITS:	mm	TITLE: T-FLASH外焊 PUSH 包装图	DWG NO: /			
THESE DRAWINGS AND SPECIFICATIONS ARE THE PROPERTY OF XFCN AND SHALL NOT BE REPRODUCED, COPIED OR CUED IN ANY MANNER WITHOUT THE PRIOR WRITTEN CONSENT OF XFCN		APPD	Chen ZhiQiang	VIEW		
		CHKD	Liu Wei	SCALE	SHEET	
		DRAW	Chen HongJiang	SCALE	SHEET	REV
		DATE	2024.08.19	NONE	2/2	A1