

RoHS

REV	ECN NO.	DESCRIPTION	DESIGN	APPROVAL	DATE
A1	NEW	更换图框			2023.11.25

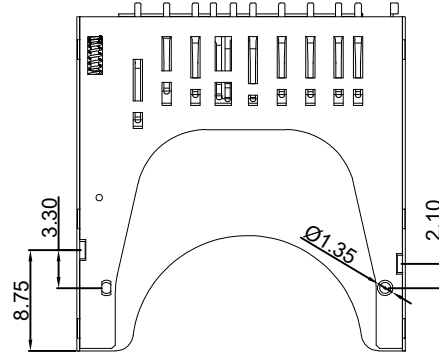
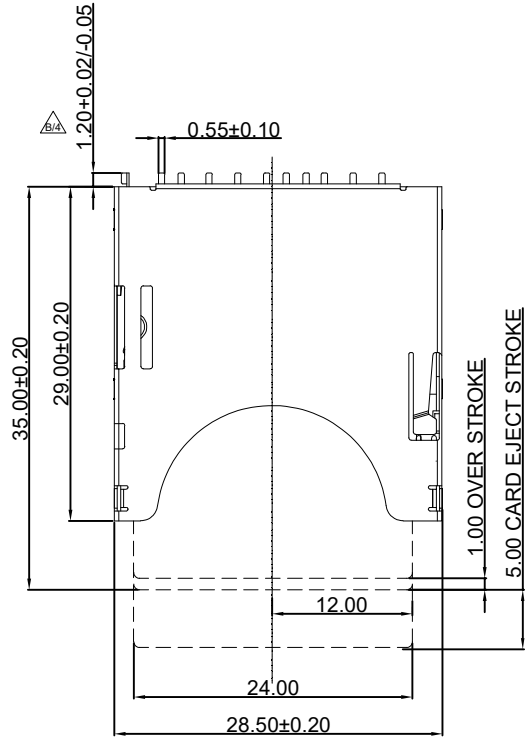
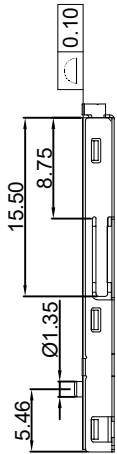

NOTES:
 1.MATERIAL:
 HOUSING: HIGH TEMPERATURE THERMOPLASTIC UL94V-0,COLOR:BLACK
 CONTACT: COPPER ALLOYS
 COVER: COPPER ALLOYS OR STEEL
 2.PLATING:
 UNDERPLATE: NICKEL
 CONTACT AREA: GOLD OVER NICKEL
 SOLDER AREA: TIN OVER NICKEL
 3.MULTIMEDIA CARD COMPATIBLE

Ordering Code:
 SDP11-N1S1-1000-A
 1 2

- 1.电镀方式
 S1=端子半金雾锡
 F1=端子镀全金
- 2.包装方式
 1=吸塑盘装
 2=载带装

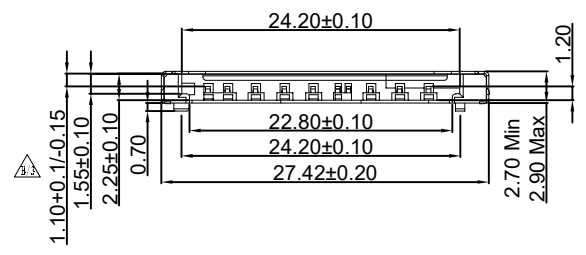
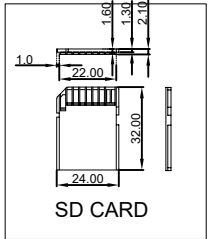
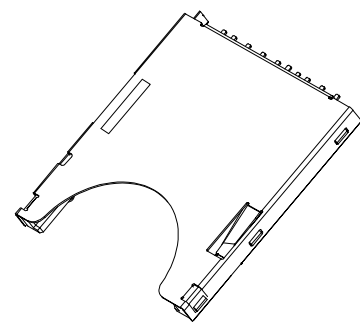

X. 0.3	X.°±	PART NO: SDP11-N1S1-1000-A		XFCN 兴飞连接器			
. XX±0.2	.XX°±	TITLE: SD PUSH 卡座		0769-82001899			
. XXX±0.03	.XXX°±			www.xfconn.com			
UNITS:	mm			DWG NO: /			
THESE DRAWINGS AND SPECIFICATIONS ARE THE PROPERTY OF XFCN AND SHALL NOT BE REPRODUCED, COPIED OR CUED IN ANY MANNER WITHOUT THE PRIOR WRITTEN CONSENT OF XFCN		APPD	Chen ZhiQiang		VIEW		
		CHKD	Liu Wei				
		DRAW	Chen HongJiang		SCALE	SHEET	REV
		DATE	2024.08.19		NONE	1/3	A1

RoHS

REV	ECN NO.	DESCRIPTION	DESIGN	APPROVAL	DATE
A1	NEW	更换图框			2023.11.25

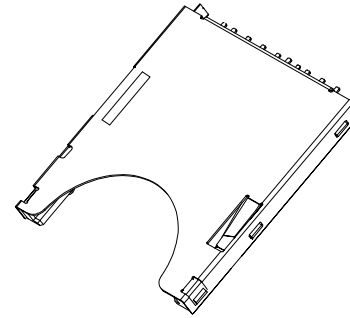
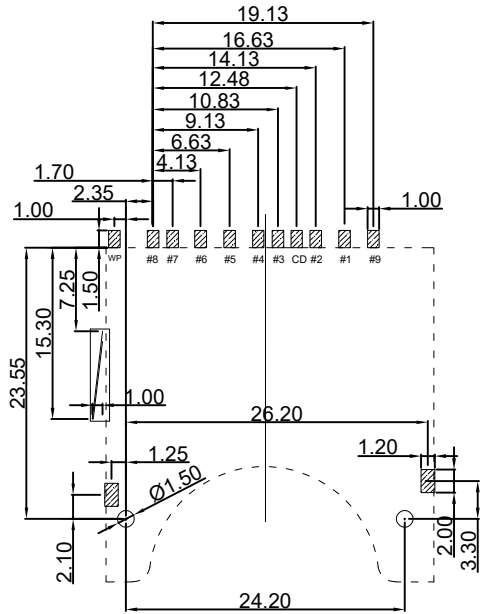

- NOTES:
- MATERIAL:
HOUSING: HIGH TEMPERATURE THERMOPLASTIC UL94V-0,COLOR:BLACK
CONTACT: COPPER ALLOYS
COVER: COPPER ALLOYS OR STEEL
 - PLATING:
UNDERPLATE: NICKEL
CONTACT AREA: GOLD OVER NICKEL
SOLDER AREA: TIN OVER NICKEL
 - MULTIMEDIA CARD COMPATIBLE

Ordering Code:
SDP11-N1S1-1000-A
1 2

- 电镀方式
S1=端子半金雾锡
F1=端子镀全金
- 包装方式
1=吸塑盘装
2=载带装

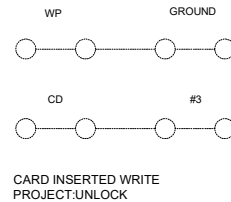
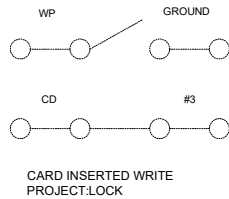
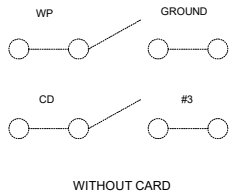

SD CARD PIN DESIGN				X.0.3	X.°±	PART NO: SDP11-N1S1-1000-A		XFCN 兴飞连接器			
PIN NO.	NAME	TYPE	DESCRIPTION	.X±0.2	.X°±	TITLE: SD PUSH 卡座		0769-82001899			
#1	CD/DAT3	I/O/PP	CARD DETECT/DATA LINE BIT3	.XX±0.08	.XX°±			www.xfconn.com			
#2	CMD	PP	COMMAN/RESPONSE	.XXX±0.03	.XXX°±			DWG NO: /			
#3	VSS1	S	SUPPLY VOL TAGE GROUND	UNITS:	mm	APPD	Chen ZhiQiang				
#4	VDD	S	SUPPLY VOL TAGE	THESE DRAWINGS AND SPECIFICATIONS ARE THE PROPERTY OF XFCN AND SHALL NOT BE REPRODUCED, COPIED OR CUED IN ANY MANNER WITHOUT THE PRIOR WRITTEN CONSENT OF XFCN		CHKD	Liu Wei	VIEW			
#5	CLK	I	CLOCK			DRAW	Chen HongJiang	SCALE	SHEET	REV	
#6	VSS2	S	SUPPLY VOL TAGE GROUND			DATE	2024.08.19	NONE	1/3	A1	
#7	DATO	I/O/PP	DATA LINE(BIT0)								
#8	DAT1	I/O/PP	DATA LINE(BIT1)								
#9	DAT2	I/O/PP	DATA LINE(BIT2)								

RoHS

REV	ECN NO.	DESCRIPTION	DESIGN	APPROVAL	DATE
A1	NEW	更换图框			2023.11.25

每盘40PCS 吸塑盘

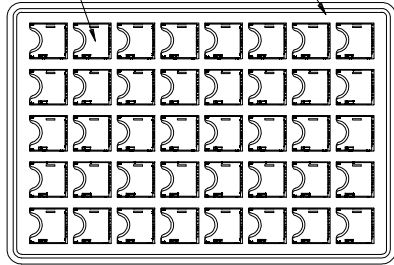

吸塑盘规格: 303*193*8MM

NO. 1

三道保护膜

顶盖

25层 (1000PCS)

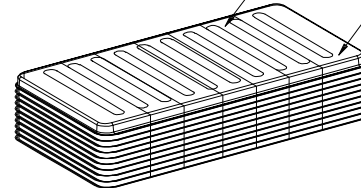

NO. 2

每2扎为一箱, 每箱装成品2000PCS

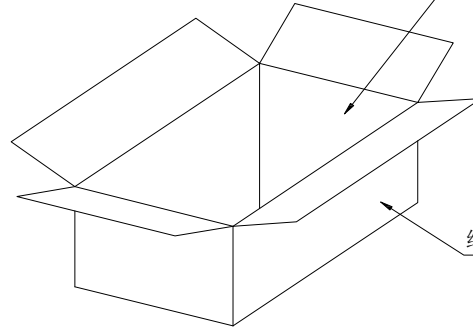

纸箱

NO. 3

胶纸封箱

成品标签

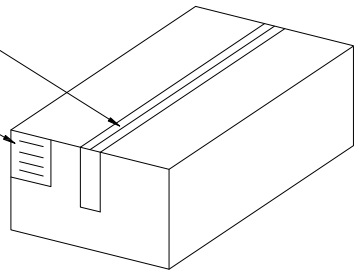

NO. 4

1. 材质要求:

1.1 纸箱的材质为A=A; 外形尺寸为32*20.5*26cm;

1.2 PS盘的材质为PS, PS盘的外形尺寸303*193+8mm;

2. 包装要求

2.1 每一盘装40PCS;

2.2 每25盘累叠在一起, 共计1Ksct; 上面需放一个空盘 后用PE膜缠绕;

2.3 把累叠好的PS盘放入纸箱中;

2.4 把包装好的成品打包封箱, 并在纸箱中贴上标签;

X. 0. 3	X. °±	PART NO: SDP11-N1S1-1000-A	XFCN 兴飞连接器						
. X ± 0. 2	. X ° ±					TITLE: SD PUSH 卡座 包装图	0769-82001899		
. XX ± 0. 08	. XX ° ±						www.xfconn.com		
. XXX ± 0. 03	. XXX ° ±						DWG NO: /		
UNITS:	mm	APPD	Chen ZhiQiang		VIEW				
THESE DRAWINGS AND SPECIFICATIONS ARE THE PROPERTY OF XFCN AND SHALL NOT BE REPRODUCED, COPIED OR CUED IN ANY MANNER WITHOUT THE PRIOR WRITTEN CONSENT OF XFCN		CHKD	Liu Wei						
		DRAW	Chen HongJiang				SCALE	SHEET	REV
		DATE	2024.08.19				NONE	3/3	A1